

Sanguinololu 1.2 Build Guide

©2011 Vincent Sanders <vince@kyllikki.org>

Revision 40 - 22/07/2011

This is a simplified build guide for the [Sanguinololu](#) electronics stepper motor controller board. It documents the build for a FTDI USB connected build using screw type connections with a voltage regulator for 5V supply. Other less common build options are possible with this board but are not documented here.

This guide only covers version 1.2 of the design, other editions exist but are not discussed here.

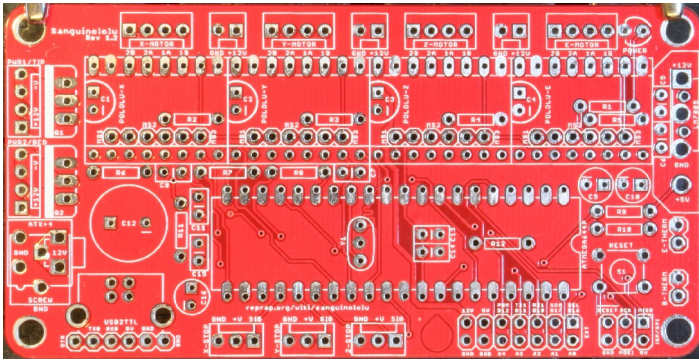

Illustration 1: Sanguinololu 1.2 PCB top surface

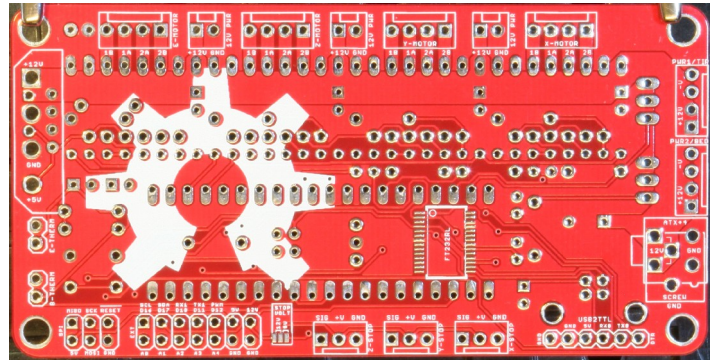

Illustration 2: Sanguinololu 1.2 PCB bottom surface

I created this guide after seeing the problems several teams had building this board at the eMaker 2011 Reprap masterclass in bath. The guide is aimed at the novice builder and not the experienced members of the community. (If you know what you are doing why are you reading this anyway :-)

I have tried to make the steps logical and group all the same type of components together for ease of construction. The Sanguinololu wiki page has a bill of materials and where components can be ordered from.

I assume the reader has some basic knowledge of soldering technique, this is not really a great “first time” project as the components are packed in pretty densely.

Licence

This work is licensed under the [Creative Commons Attribution-ShareAlike 3.0 Unported License](#).

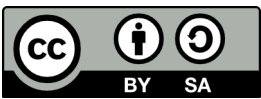

Getting Prepared

For a good build of any electronics project you should prepare some things:

- A clear, well lit work area, preferably well ventilated too – solder fumes are not good for you.
- A fine tipped soldering iron.
- Suitable bit cleaning material either a wetted sponge or metal wick.
- Ideally some “helping hands” or similar. Soldering is one of those activities where you need three hands so something to hold the workpiece is useful.
- Suitable fine multi core solder wire (solder wire with flux embedded within)
- Good pair of side snip pliers.

It is useful to have a map of component locations and their reference designator so once you have soldered components into a board you do not need to reference the now obscured silkscreen.

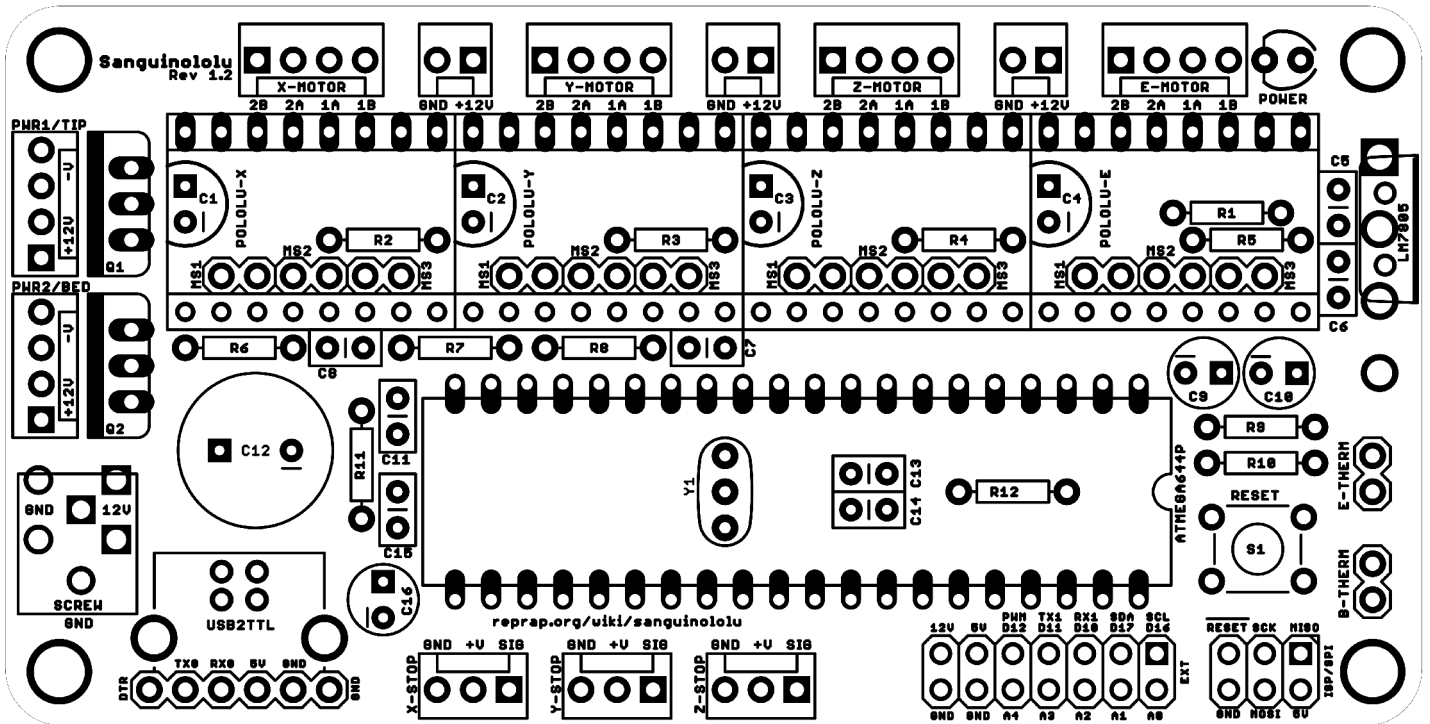

Illustration 3: Sanguinololu Component Identification

It can also be useful to print the component ident out and use a coloured marker to mark off when you place a component so you can ensure you have not missed anything.

Some builders like to use a short length of electrical tape to ensure components do not fall out of the board when they turn it over to solder the leads.

Build Method

Start by cleaning the PCB using a suitable solvent (I use a specific purpose residue PCB cleaner but acetone would also work). Try to avoid abrasive “rubber” type cleaners as they leave fine metal filings and swarf behind which is undesirable.

The first operation is to mount the FTDI chip. I would advise that anyone unsure about mounting surface mount components either purchase the board with the component fitted or carefully study the [technique used by Joem](#) in his video.

After mounting this component clean the board of any excess flux or residues again, being careful not to disturb the FTDI chip. The device should be fairly robust but it is static sensitive and excess handling should be avoided.

All the remaining components are simple through hole devices. All the passive components (resistors and capacitors) are not sensitive to static but you should try and handle their leads as little as possible as the natural oils on your skin are very good at causing “dry” joints.

Ensure the polarised components are inserted in the correct orientation, especially important for the electrolytic capacitors which will work somewhat when inserted the wrong way down but will rapidly deteriorate.

The suggested build order means that each component should be easy to place and give easy access to its legs for soldering.

Components should be mounted as close to the board as possible. This reduces the likelihood of unintentional connections, produces a neater build and reduces undesirable capacitance and noise from over long leads.

After soldering each component the joints should be a shiny cone shape which has “wicked” up the leg of the component. If the joint appears dull or the lead appears to not be joined properly let the joint cool, clean your iron tip, reapply heat and more solder. If you get too much solder on the joint use solder wick to remove it all and try again. Do not leave such joints for later, make sure they are right and there are no unintended solder “bridges” or “whiskers” between soldered joints.

Once you are happy with a through hole components joint use your wire snips and clip the lead just above the solder “cone”. Do not be tempted to leave excess lead length, it is not useful and causes short circuit hazards and makes soldering the next component difficult.

The SIL pins and sockets and the IC DIP socket will probably not require clipping to length.

Testing

Once soldering is complete but before fitting the micro controller IC or the pololu stepper driver boards some basic tests can be performed.

Use a multimeter set on resistance to check the resistance between ground and the power supply rails. If using a beep test the meter may sound for a short period while charging the supply capacitors. There should be a high resistance between the rails (not shorted together). Be aware that the voltage regulator catch diodes means that it may conduct in the reverse direction so do not be fooled by that.

If there is a short circuit visually examine the soldering for bridges being especially careful of joints around the power supply input end of the board near the heater FET devices.

The main supply power should now be connected to JP22 screw terminal. If you have access bench supply that can current limit set it at approximately 20mA limit. Alternatively if you have a second meter capable of measuring current place it in the supply input, this meter should be continuously monitored for excessive current usage. If you can do neither of these things then you must be ready to turn the power off quickly if components start to overheat or smoke.

A meter should be set to measure voltage in the 5 volt range and the ground probe attached to the centre pin of the voltage regulator and the positive probe to the pin closest to the centre of the board. Turn the input supply power on. The meter should read 5V. If not immediately disconnect the power and check the voltage regulator component orientation and solder connections.



Once you have a working 5V rail check that the voltage between pin 10 and pin 31 of the 40 pin DIP socket is also 5V.

Insert the ATmega 644p chip and connect the USB lead. The FTDI serial port should appear and you can now communicate with the ATmega (It may need initial programming) and all is good.



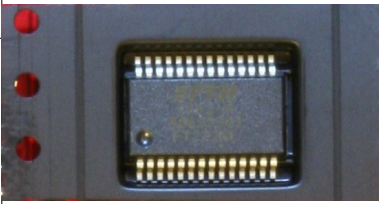
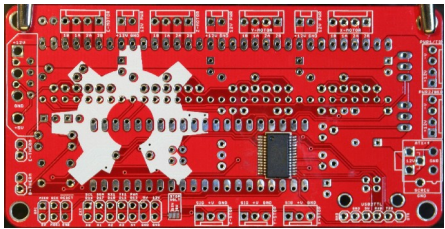
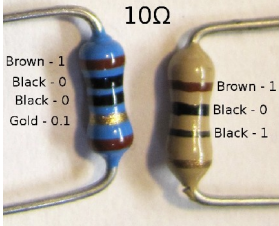
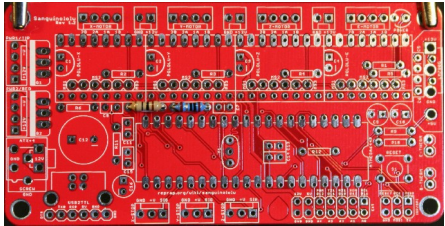
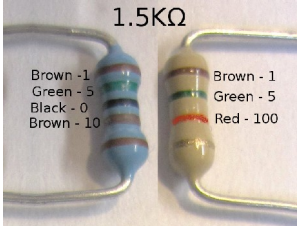
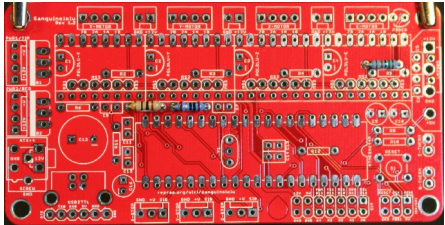
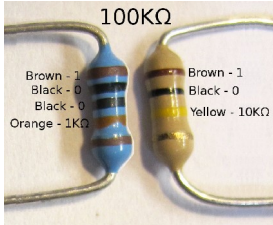
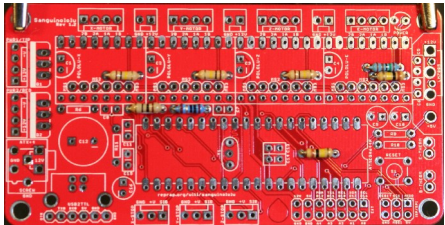

There are many more possible failure modes but that covers the main ones.

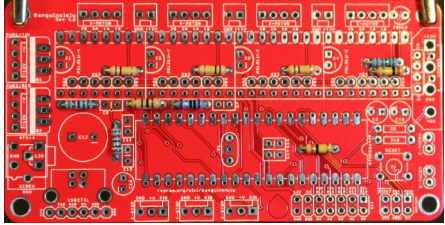
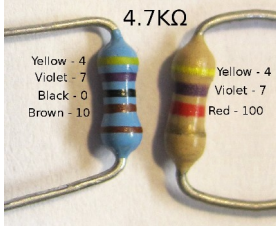
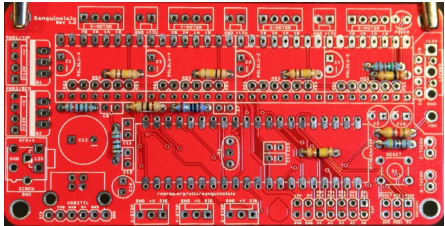

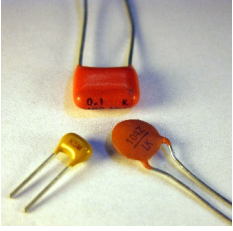
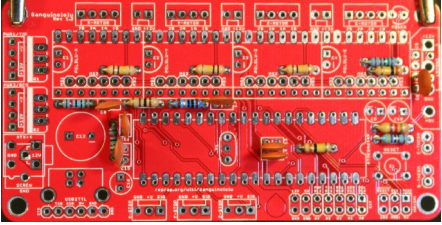
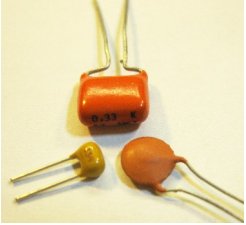
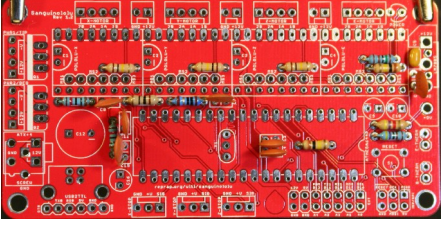
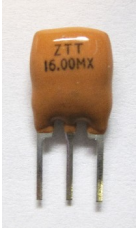
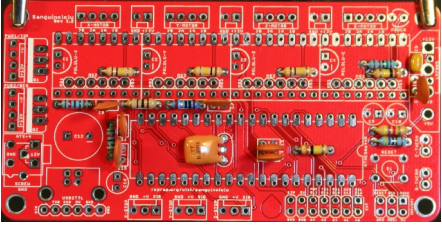
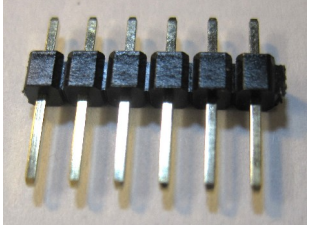
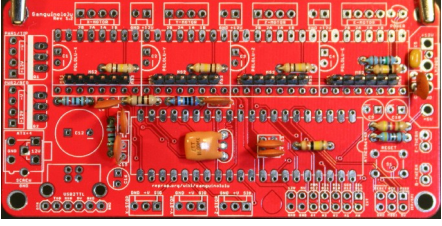
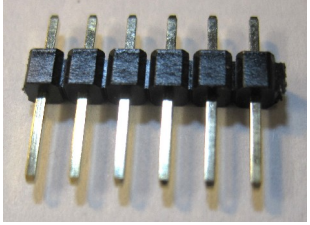
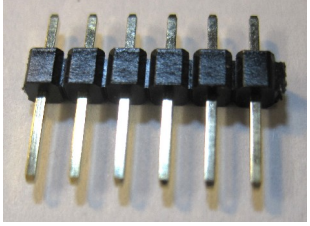
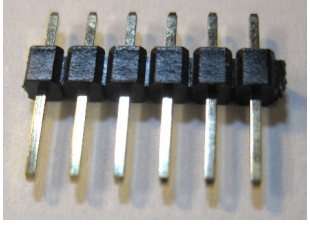

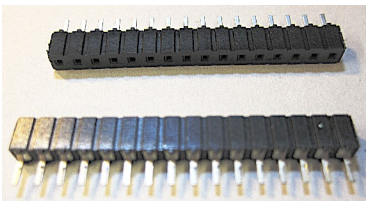
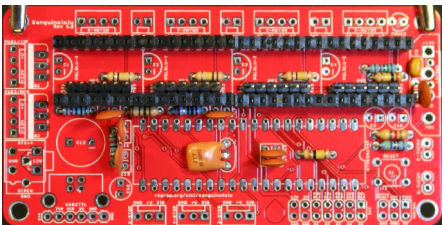
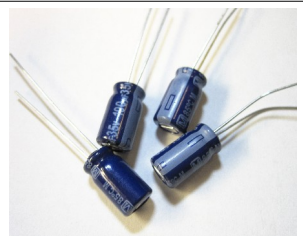
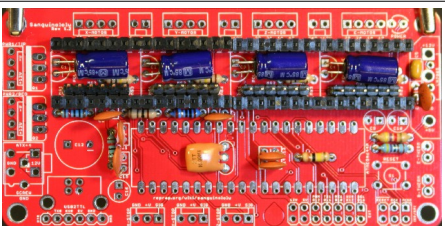

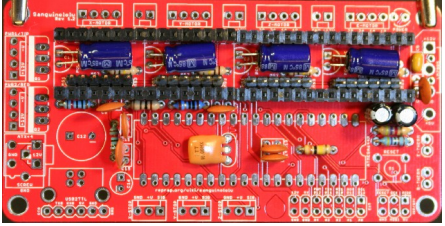
Building

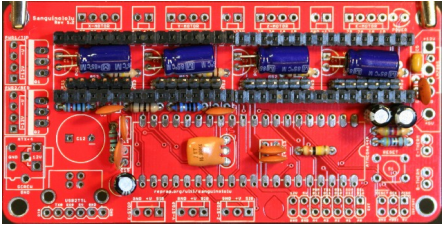
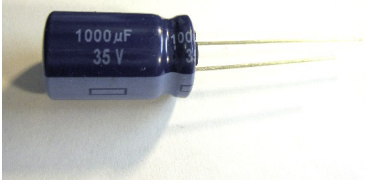
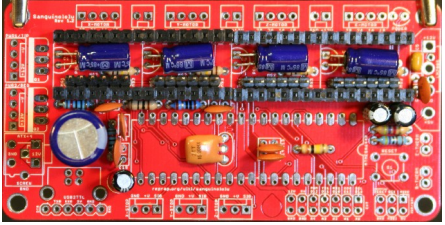
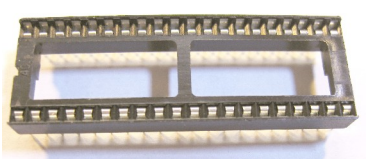
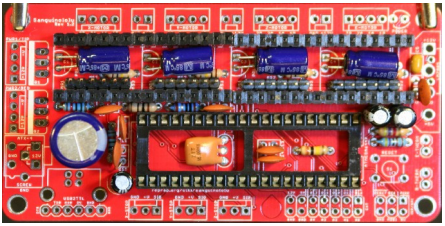
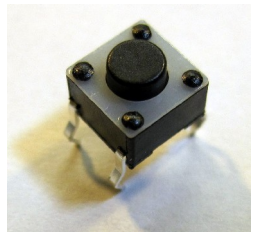
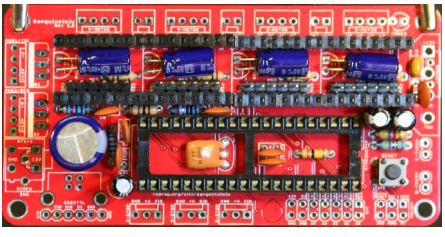

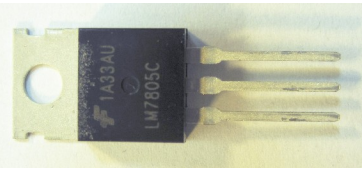
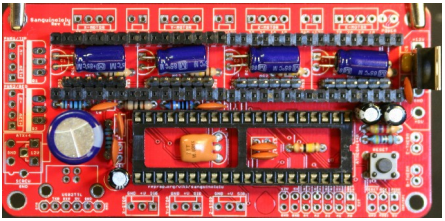
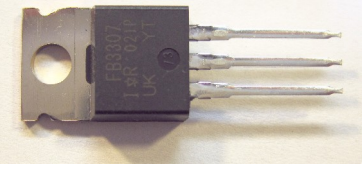
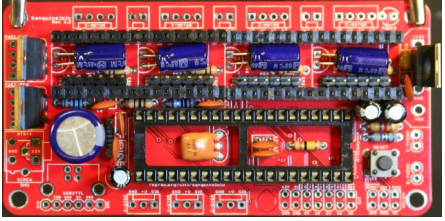
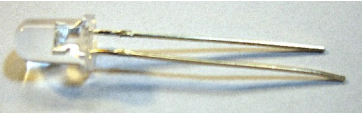
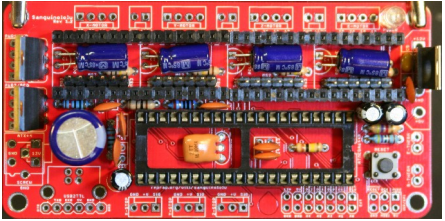

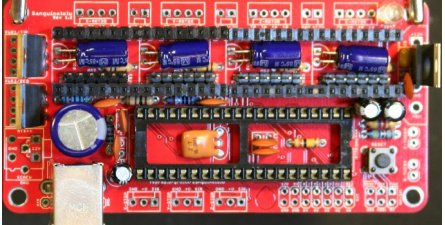
Fit each component in order according to this table.

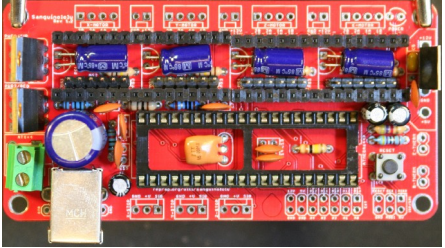
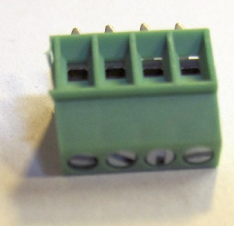
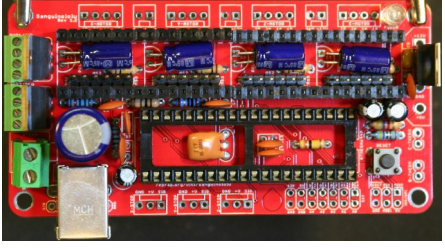
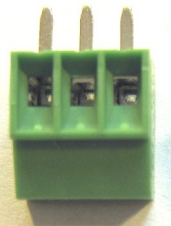
| Part | Value | Device | Notes | Board |
|-------|---------|---|---|---|
| IC100 | FT232RL |  | Surface mounted on the underside of the board. |  |
| R7 | 10Ω |  <p>10Ω</p> <p>Brown - 1 Black - 0 Black - 0 Gold - 0.1</p> <p>Brown - 1 Black - 0 Black - 1</p> | ¼ Watt Axial Resistor. This is used as a series damping resistor in the serial receive and transmit lines. It must be of a low value (10-33 ohms) and not the 1Kohm value specified in the schematic or serial communications will not function properly. |  |
| R8 | 10Ω | | | |
| R1 | 1.5KΩ |  <p>1.5KΩ</p> <p>Brown - 1 Green - 5 Black - 0 Brown - 10</p> <p>Brown - 1 Green - 5 Red - 100</p> | ¼ Watt Axial Resistor |  |
| R2 | 100KΩ |  <p>100KΩ</p> <p>Brown - 1 Black - 0 Black - 0 Orange - 1KΩ</p> <p>Brown - 1 Black - 0 Yellow - 10KΩ</p> | ¼ Watt Axial Resistor |  |
| R3 | 100KΩ | | | |
| R4 | 100KΩ | | | |
| R5 | 100KΩ | | | |
| R12 | 100KΩ | | | |
| R6 | 10KΩ |  <p>10KΩ</p> <p>Brown - 1 Black - 0 Black - 0 Red - 100</p> <p>Brown - 1 Black - 0 Orange - KΩ</p> | ¼ Watt Axial Resistor |  |
| R11 | 10KΩ | | | |
| R9 | 4.7KΩ |  <p>4.7KΩ</p> <p>Yellow - 4 Violet - 7 Black - 0 Brown - 10</p> <p>Yellow - 4 Violet - 7 Red - 100</p> | ¼ Watt Axial Resistor |  |
| R10 | 4.7KΩ | | | |

| | | | | |
|------|--------|---|--|---|
| C6 | 0.1µF |  | 0.1uF/100nF tantalum bead, metal film or ceramic disc capacitor. Often marked as 104 (10×10^4 pF) or 0.1K (0.1 thousand nF). Metal film type will be difficult to fit in this design. |  |
| C7 | 0.1µF | | | |
| C8 | 0.1µF | | | |
| C11 | 0.1µF | | | |
| C13 | 0.1µF | | | |
| C14 | 0.1µF | | | |
| C15 | 0.1µF | | | |
| C5 | 0.33µF |  | 0.33uF/330nF tantalum bead, metal film or ceramic disc capacitor. Often marked as 334 (33×10^4 pF) or 0.33K (0.33 thousand nF). Metal film type will be difficult to fit in this design. |  |
| | | | | |
| Y1 | 16MHz |  | 16MHz ceramic resonator. Colour and markings vary between manufacturers. |  |
| | | | | |
| JP9 | X-MS1 |  | Each block of three two pin headers have been merged into a single six pin Single In Line (SIL) pin header to make assembly easier. There are four of these on the design all identical. |  |
| JP10 | X-MS2 | | | |
| JP11 | X-MS3 | | | |
| | | | | |
| JP12 | Y-MS1 |  | | |
| JP13 | Y-MS1 | | | |
| JP14 | Y-MS1 | | | |
| | | | | |
| JP15 | Z-MS1 |  | | |
| JP16 | Z-MS1 | | | |
| JP17 | Z-MS1 | | | |
| | | | | |
| JP18 | E-MS1 |  | | |
| JP19 | E-MS1 | | | |
| JP20 | E-MS1 | | | |
| | | | | |

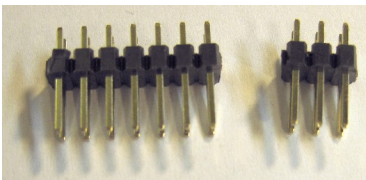
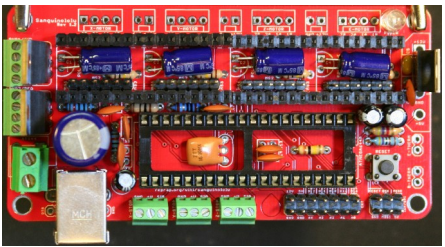
| | | | | |
|-----|-----------|---|--|---|
| P1 | POLOLU-X |  | Each of the four Pololu stepper driver boards will be mounted using 0.1inch (2.54mm) spaced SIL sockets. For ease of assembly the sockets on the board are grouped into four sixteen pin strips. |  |
| P2 | POLOLU-Y | | | |
| P3 | POLOLU-Z | | | |
| P4 | POLOLU-E | | | |
| C1 | 100μF |  | Aluminium Electrolytic capacitors with at least 35V rating. Negative lead is usually indicated by being the shorter of the two and often markings on component body |  |
| C2 | 100μF | | | |
| C3 | 100μF | | | |
| C4 | 100μF | | | |
| C9 | 10μF |  | Aluminium Electrolytic capacitors with at least 35V rating. Negative lead is usually indicated by being the shorter of the two and often markings on component body |  |
| C10 | 10μF | | | |
| C16 | 4.7μF |  | Aluminium Electrolytic capacitors with at least 35V rating. Negative lead is usually indicated by being the shorter of the two and often markings on component body |  |
| C12 | 1000μF |  | Aluminium Electrolytic capacitors with at least 35V rating. Negative lead is usually indicated by being the shorter of the two and often markings on component body |  |
| IC2 | 40pin Skt |  | ATMEGA644 socket careful attention should be paid to the polarity of the socket. |  |
| SW1 | |  | Reset push button switch. |  |

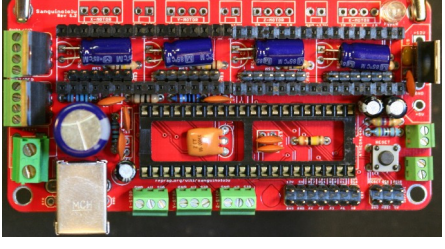
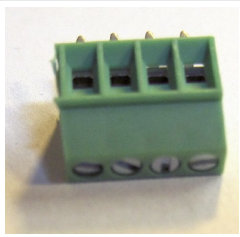
| | | | | |
|------|------------|---|--|---|
| IC1 | LM7805 |  | Voltage Regulator |  |
| Q1 | RFP30N06LE |  | N-Channel mosfet |  |
| Q2 | RFP30N06LE | | | |
| LED1 | LED |  | 3-5mm LED for power indication |  |
| J1 | USB |  | USB B socket |  |
| JP23 | 2pin screw |  | Main power, connectors. The connectors shown here are 5mm pitch screw terminal blocks. Other types of connectors such as simple pin headers or crimped locking connectors may be used instead. |  |
| JP8 | HOTEND |  | Tip and bed heater connectors. The connectors shown here are 2.54mm pitch screw terminal blocks. Other types of connectors such as simple pin headers or crimped locking connectors may be used instead. |  |
| JP21 | HOTBED | | | |
| JP27 | X-Stop |  | Three pin 2.54mm pitch screw terminal. |  |
| JP28 | Y-Stop | | | |
| JP29 | Z-Stop | | | |

| | | | | |
|------|------------|---|---------------------------------------|---|
| U24 | ISP Header |  | 2x7 pin and 2x3 0.1inch pitch headers |  |
| U24 | Extension | | | |
| JP22 | E-Therm |  | Thermistor input terminals |  |
| JP24 | B-Therm | | | |
| JP1 | MOT-X |  | Motor connections |  |
| JP3 | MOT-Y | | | |
| JP5 | MOT-Z | | | |
| JP7 | MOT-E | | | |